

THE GENERAL RADIO EXPERIMENTER

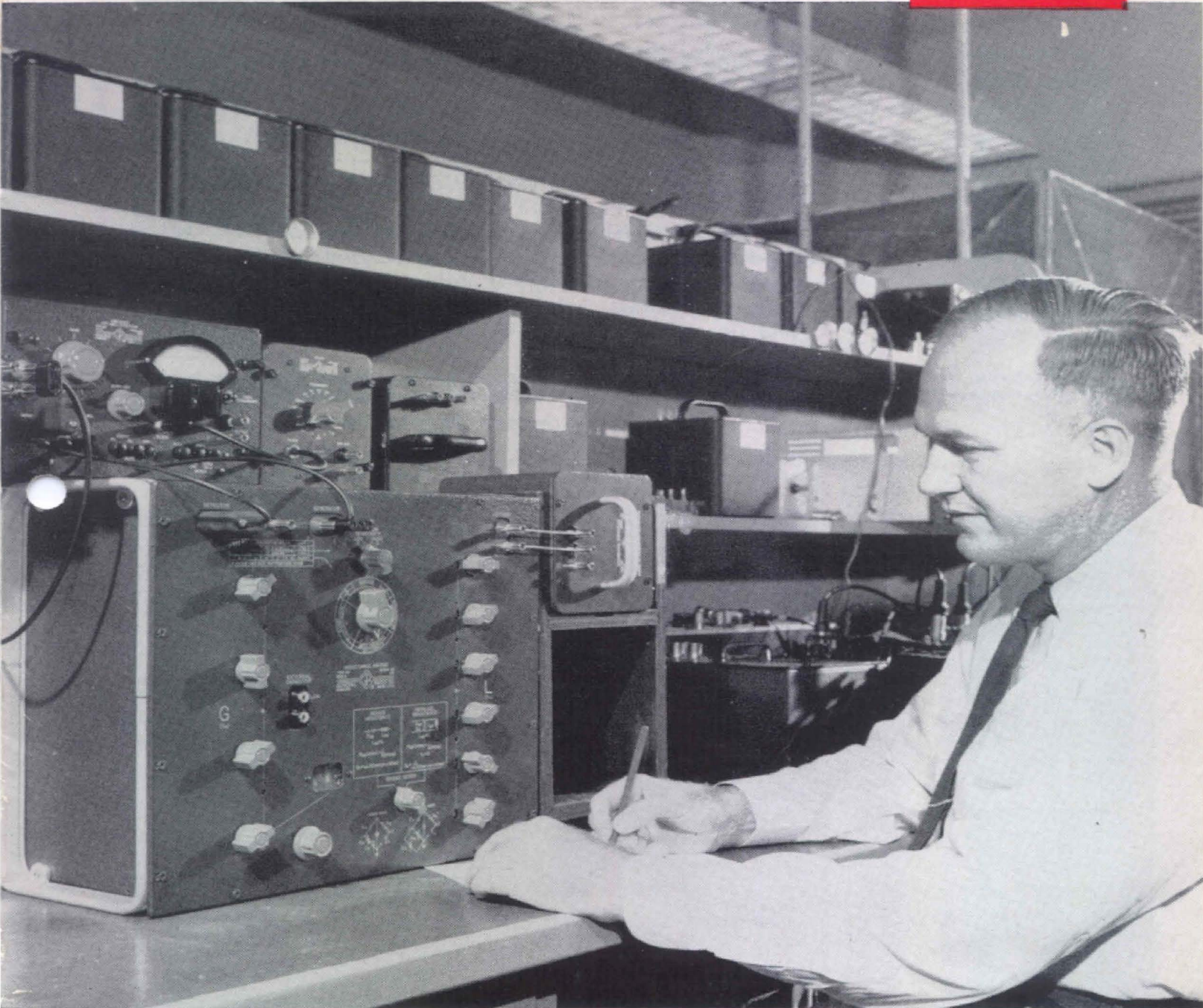

VOLUME 33 No. 11

NOVEMBER, 1959

IN THIS ISSUE



Inductance Bridge
Export Packing
Delay-Line Oscillator



©1959—GENERAL RADIO COMPANY, WEST CONCORD, MASS., U.S.A.

Published Monthly by the General Radio Company

VOLUME 33 • NUMBER 11

NOVEMBER, 1959

CONTENTS

	Page
A Bridge for the Precise Measurement of Inductance . . .	3
Have Protection — Will Travel	9
Delay-Line Oscillator	11
New Representative for Belgium and Luxemburg	12

The General Radio EXPERIMENTER is mailed without charge each month to engineers, scientists, technicians, and others interested in electronic techniques in measurement. When sending requests for subscriptions and address-change notices, please supply the following information: name, company address, type of business company is engaged in, and title or position of individual.

GENERAL RADIO COMPANY

West Concord, Massachusetts

Telephone: (Concord) EMerson 9-4400; (Boston) CLeArwater 9-8900

- NEW YORK:** Broad Avenue at Linden, Ridgefield, New Jersey
Telephone — N. Y., WOrth 4-2722
N. J., WHitney 3-3140
- CHICAGO:** 6605 West North Avenue, Oak Park, Illinois
Telephone — VillAge 8-9400
- PHILADELPHIA:** 1150 York Road, Abington, Pennsylvania
Telephone — HAncock 4-7419
- WASHINGTON:** 8055 13th St., Silver Spring, Maryland
Telephone — JUniper 5-1088
- LOS ANGELES:** 1000 North Seward St., Los Angeles 38, Calif.
Telephone — HOllYwood 9-6201
- SAN FRANCISCO:** 1186 Los Altos Ave., Los Altos, Calif.
Telephone — WHitecliff 8-8233
- CANADA:** 99 Floral Parkway, Toronto 15, Ontario
Telephone — CHerry 6-2171

REPAIR SERVICES

- EAST COAST:** General Radio Co., Service Dept., 22 Baker Avenue,
West Concord, Mass.
Telephone — Concord, EMerson 9-4400
Boston, CLeArwater 9-8900
- NEW YORK:** General Radio Co., Service Dept., Broad Ave. at
Linden, Ridgefield, New Jersey
Telephone — N. Y., WOrth 4-2722
N. J., WHitney 3-3140
- MIDWEST:** General Radio Co., Service Dept., 6605 West North
Ave., Oak Park, Illinois
Telephone — VillAge 8-9400
- WEST COAST:** Western Instrument Co., 826 North Victory Boule-
vard, Burbank, Calif.
Telephone — VICTORIA 9-3013
- CANADA:** Bayly Engineering, Ltd., First St., Ajax, Ontario
Telephone — Toronto EMpire 2-3741

COVER



John F. Hersh, author of the article describing the new precision inductance bridge, is shown operating the bridge in the General Radio standards laboratory.



A BRIDGE FOR THE PRECISE MEASUREMENT OF INDUCTANCE

TYPE 1632-A INDUCTANCE BRIDGE

The instrument manufacturer who makes resistors, capacitors, and inductors of high accuracy and low residual impedance has both the need and the opportunity to build the impedance bridges required for high-accuracy measurements of these components. The General Radio Company has for many years been building, and continually improving in accuracy and stability, the TYPE 510 Decade-Resistance Units¹ which are used in the TYPE 1432 Decade Resistors. The materials and winding

methods used in these units produce not only the excellent stability and low temperature coefficient required for a significant accuracy of $\pm 0.05\%$, but also the small residual reactances which permit use of the resistors over a wide frequency range. Fixed standards of capacitance have also undergone a continuous process of improvement, and the current silvered-mica TYPE 1409 Standard Capacitors² are accurate to $\pm 0.05\%$, with a long-term stability of better than 0.01%.

¹Ivan G. Easton, "The New TYPE 1432 Decade Resistors," *General Radio Experimenter*, June, 1951, Vol. XXVI, No. 1.

²Ivan G. Easton and P. K. McElroy, "New Silvered-Mica Standard Capacitors," *General Radio Experimenter*, July, 1957, Vol. 32, No. 2.

Figure 1. Panel view of the Type 1632-A Inductance Bridge.

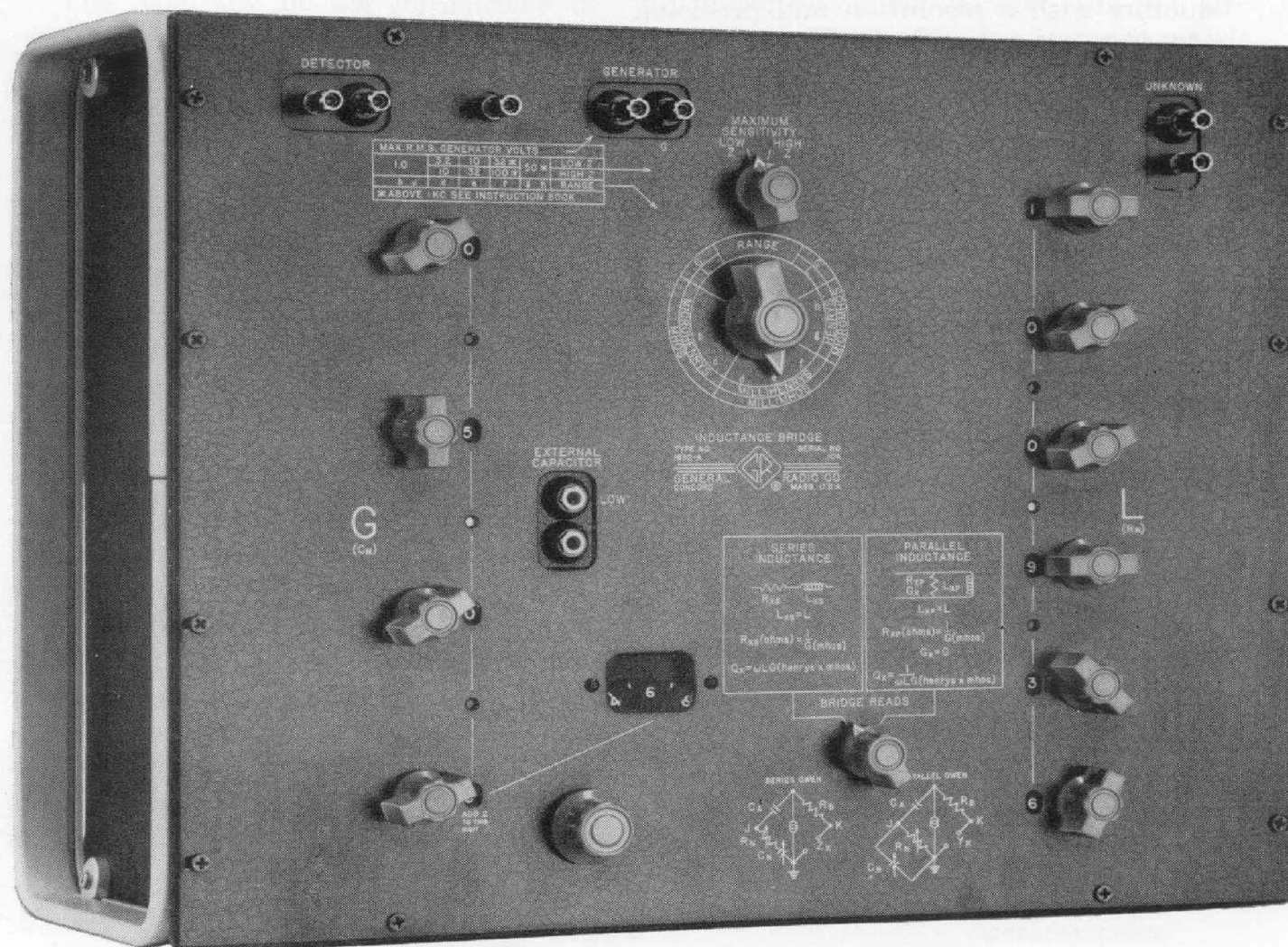

Another recent addition to the General Radio line of precision components is a series of highly accurate and stable standard inductors.³ The TYPE 1482 Standard Inductors, being toroidally wound on ceramic cores and shielded from external thermal, mechanical, atmospheric, and electrical disturbances, have the high stability and reliability⁴ that make possible their calibration with the closest tolerance ($\pm 0.03\%$) that the National Bureau of Standards will place on its certification of absolute inductance. For General Radio to certify the inductance of these inductors with the same accuracy limit of $\pm 0.03\%$, the inductors must be intercompared with a set of NBS-calibrated inductors with a precision of higher order than the tolerance. This need for the measurement of inductance over the 100- μ h to 10-h range of the TYPE 1482 Standard Inductors with a resolution and precision of 0.003% or better led to the construction for our standardizing laboratory of a new inductance bridge, which made use of our wide range of precision resistors and standard capacitors to measure the inductors. With improvements that make it more convenient to use and more generally useful, this new, wide-range, high-precision bridge is now being produced as the TYPE 1632-A Inductance Bridge.

For inductance standardization as well as for general inductance measurement, this bridge approaches the ideal, not only in inductance range and accuracy, but also in speed and convenience of operation. Two important features are digital in-line readout and the inclusion of operational data and circuit schematic on the panel.

³Horatio W. Lamson, "A New Series of Standard Inductors," *General Radio Experimenter*, November, 1952, Vol. XXVII, No. 6.

⁴Horatio W. Lamson, "Standard Inductors, a Stability Record," *General Radio Experimenter*, May, 1957, Vol. 31, No. 12.

An Owen Bridge

This bridge uses the Owen bridge circuit in which the inductance balance is made with precision decades of resistance, thus achieving a high degree of resolution and a high accuracy at moderate cost. The other bridge circuits commonly used for inductance measurement, the Maxwell and the Hay, require variable capacitors for the inductance balance, and capacitors of the desired range and accuracy are very expensive. In the Owen bridge shown in Figure 2, the fixed arms consist of the standard capacitor C_A and the resistor R_B . The unknown Z_X is balanced by the decade resistor R_N and decade capacitor C_N , and at balance the unknown is related to the standards by the equations:

$$L_X = (C_A R_B) R_N \quad (1)$$

$$G_X = \frac{1}{C_A R_B} C_N \quad (2)$$

The decades can be switched to either a series or a parallel connection, so that the bridge can be made direct reading in either series or parallel components of the unknown inductor. When the resistance and capacitance decades are connected in series, the equivalent series inductance, L_{XS} , and series conductance, G_{XS} , of the unknown Z_X are proportional to R_N and to C_N ; when the standards are connected in parallel, R_N and C_N determine the equivalent parallel inductance, L_{XP} , and parallel conductance, G_{XP} . The equivalent resistance in either configuration is the reciprocal of the conductance, $R_X = 1/G_X$. Over a wide range of Q , the unknown can be measured in terms of whichever components are most convenient. Even when the Q is very high or very low, a balance for one of the equivalents can usually be obtained. When the Q is very low, the series components can usually be measured; when the Q is



very high, the parallel components can be measured.

The variable standard resistance R_N consists of six TYPE 510 Decade Resistance Units in 10-kilohm to 0.1-ohm steps, with a calibration accuracy of $\pm 0.05\%$ in all except the two lower decades. Since the measured inductance is proportional to this resistance, these six decades give the bridge a resolution of inductance up to six significant figures. The range of inductance covered by these six decades can be changed readily by a change in the $C_A R_B$ product which relates L_X to R_N . Through an eight-position range switch a choice can be made among three C_A capacitors and six R_B resistors to cover a range of full-scale inductance from 1,111 henrys to 111 microhenrys. The minimum inductance indication is, thus, seven decades below 111 microhenrys or 0.0001 microhenry.

The accuracy of the inductance indication is, of course, limited by the accuracy and stability of all of the components entering into Equation (1). The resistance R_B is made up of the same stable and accurate wire-wound resistors as are used in the decades of R_N , and the residual inductance or capacitance is compensated. Equally stable silvered-mica standard capacitor units are used for C_A . These components make possible a direct-reading bridge accuracy of 0.1% over wide ranges of inductance, Q , and frequency.

Full use can be made of the potential resolution and accuracy in inductance reading only if the resistive component of the unknown can be balanced both with comparable precision and without appreciable interaction between balances as a result of residual impedances. In the Owen bridge such resistance balance requires a variable capacitor of wide range having low losses and both loss and capacitance independent of frequency. The TYPE 1632-A Inductance Bridge is possible only because General Radio now produces high-quality polystyrene capacitors,⁵ used in the TYPE 1419-A Decade Capacitor, which have stable and constant capacitance and low dissipation factor, even at the frequencies below 100 c which are often used in inductance measurements. C_N consists of four decades of these polystyrene capacitors, in 0.1- to 0.0001- μf steps, followed by a continuously variable 130-pf* air capacitor. These decades are calibrated to an accuracy of $\pm 1\%$; better accuracy in the measurement of G is rarely needed and is usually prohibited by errors caused by bridge residuals. When a capacitance greater than 1 μf is required to balance a very high conductance, an external capacitor can be connected at panel jacks to parallel the C_N decades.

⁵"New Decade Capacitors with Polystyrene Dielectric," *General Radio Experimenter*, July, 1956, Vol. 31, No. 2.

*pf = picofarad = $\mu\mu\text{f}$.

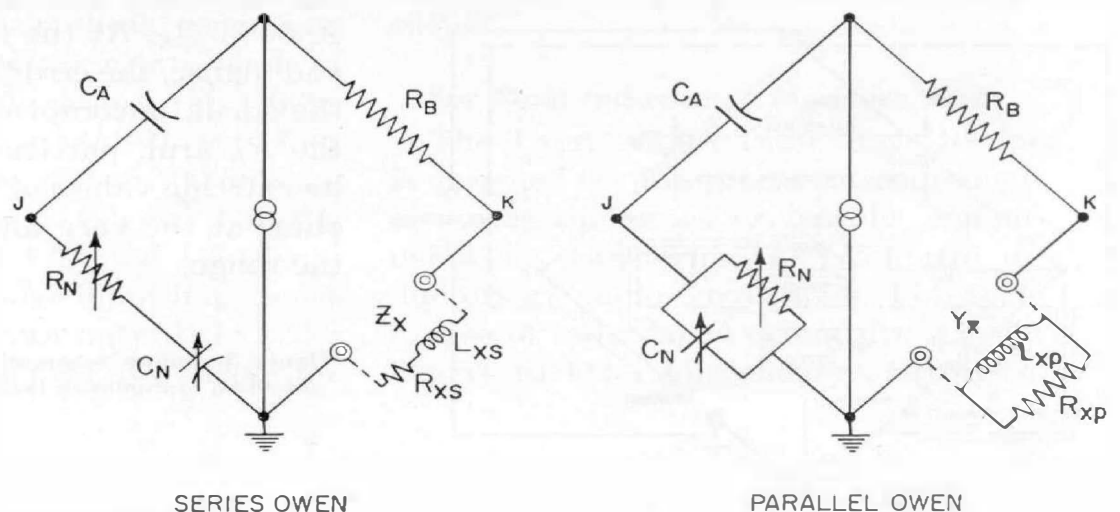

Figure 2. Elementary schematic of the Owen bridge circuits used in the Type 1632-A Inductance Bridge.

With Low Residuals

The simple, independent balance conditions, which constitute one of the advantages of the Owen bridge, can be obtained in practice only if the bridge arms are free of residual impedances. In the TYPE 1632-A Inductance Bridge many of the possible residuals are minimized by the use of capacitors with very small residual resistance and of resistors with very small residual inductance and capacitance. Other residuals are reduced or controlled by the careful internal shielding shown in Figure 3.

The most troublesome residuals are capacitances across the unknown arm and across the standards, R_N and C_N , when they are in series. These capacitances are minimized by the shield enclosing the C_A and R_B arms of the bridge. By extension of this shield into the base of the UNKNOWN terminals, the capacitance added across the unknown by the bridge is reduced to the 1-pf capacitance between the external terminals. In the "standard" arm another shield encloses the resistance decade R_N to reduce the capacitance across the series combination of R_N and C_N to the negligible value of less than a picofarad. The capacitance of this shield to ground appears across C_N and is included in the calibration of the conductance decades. This shield capacitance limits in minimum C_N to 200 pf, and results in the "ADD 2"

that appears on the instrument panel below the window of the fourth G dial.

Further special shielding within the transformer used between bridge and detector permits the detector to be grounded without additional contribution to the bridge residuals. The inter-shield capacitances of the transformer, however, add some 100 pf to the C_A arm of the bridge, which can be included in the calibration of C_A . Since the total C_A is only 1000 pf in the lowest or a range of the bridge, the lower stability and higher loss of the transformer capacitance limit somewhat the accuracy of this range. An accuracy of the order of $\pm 1\%$ can be realized on the a range, and this reduced accuracy is indicated by a red a for this multiplier position. Since the primary use of this a range is the measurement of the very low inductance of leads and of shorted terminals, the reduction in accuracy here is not detrimental.

With this control and reduction of residual impedances, the 0.1% inductance accuracy of the bridge can be maintained over wide ranges of inductance, Q , and frequency. The ranges of measurement are so wide, however, that additional errors arise from the remaining very small residuals at the extremes of the ranges. When the Q of the unknown is very low, these residuals, including the small dissipation factors of the capacitors used as C_A and C_N , can increase the inductance error by $\pm .05\%/Q_X$. At the frequencies of 10 kc and higher, the error is also increased by the small, uncompensated reactances of the R_B arm, particularly when R_B has its extreme values of 1 ohm and 100,000 ohms at the very low and high ends of the range.

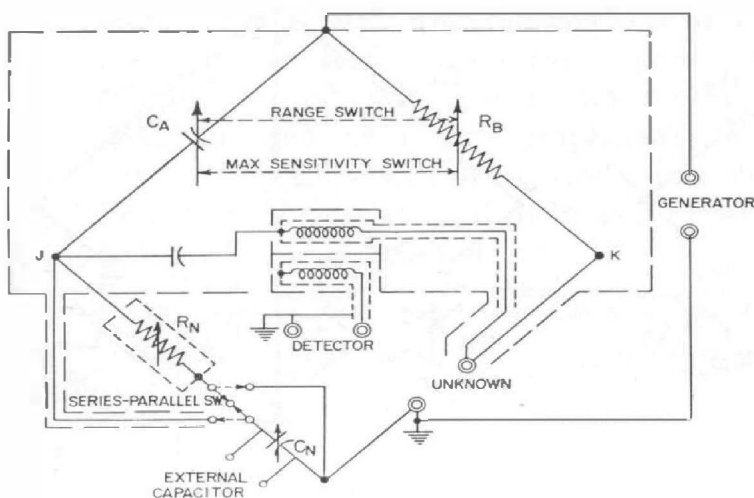

Figure 3. Bridge schematic showing the internal shielding to minimize residual-impedance errors.



Easy to Use

The TYPE 1632-A Inductance Bridge is designed not only to make measurements of high resolution and accuracy, but to make such measurements with maximum ease and rapidity. For this purpose the dials of the decades indicating L and G are arranged to show only the pertinent digit of each decade, and these digits are placed for convenient vertical, in-line, digital readout of the six significant figures. The eight-position range switch both indicates the units of L and G and automatically places the decimal point in the line of digits. Operation is further simplified, particularly for the occasional user, by the presentation on the panel of the bridge circuits and balance equations, as well as a table of the limits of maximum input voltage. The bridge can be balanced easily and rapidly to its full resolution because in an Owen bridge with such small residuals the L and G balances are independent and there is no trouble with a sliding balance and false nulls.

Neither generator nor detector is built into this bridge, because the versatility required in them to match that of the bridge can best be built into external units. Adequate generator range and power for most bridge uses can be provided by the TYPE 1304-B Beat-Frequency Audio Generator or by the combination of the TYPE 1210-C Unit R-C Oscillator and the TYPE 1206-B Unit Amplifier. Since these generators are designed for operation into loads of the order of 600 ohms and the bridge input impedance on the lower four ranges is of the order of 1 to 100 ohms, a matching transformer (TYPE 1632-P1) with turns ratios of 1:20 and 1:5 is supplied to raise the bridge input impedance to match the generator output. In order to keep its magnetic field away from the

bridge and the inductor being measured, this transformer is designed to be plugged into the generator instead of being built into the bridge.

A detector of high sensitivity and low noise is required to make use of the full six-figure resolution of this bridge. The requirements can be met by the TYPE 1231-B Amplifier and the Null Detector with the TYPE 1231-P5 Adjustable Filter, followed by a null indicator with additional gain, such as a pair of headphones, an oscilloscope, a millivoltmeter, or another TYPE 1231-B Null Detector. For measurements requiring only the direct-reading accuracy of $\pm 0.1\%$, a single TYPE 1231-B with filter is usually adequate. The maximum available sensitivity, particularly at low frequencies, has been realized by making the detector transformer impedance as high as possible and by locating the transformer to satisfy best the condition that the bridge is most sensitive when the detector is connected at the junctions of arms having equal impedances. As another aid to sensitivity, a MAXIMUM SENSITIVITY switch has been provided to, permit on some ranges a choice of the magnitude of the C_A and R_B arms to satisfy best this condition. On the middle (d , e , f) ranges, this switch changes both R_B and C_A by a factor of ten without changing their product, $C_A R_B$, and thus does not alter the multiplying factor of the bridge which has been set with the range switch.

For Most Inductance Measurements

The TYPE 1632-A Inductance Bridge is designed for the precise measurement of either the series or parallel components or two-terminal, grounded inductors at audio frequencies. Full-scale ranges of inductance extend from 1,111 henrys to 111.1 microhenrys. Six-figure



resolution and high sensitivity make this bridge particularly suitable for standardization measurements of high accuracy, since standard inductors, such as the TYPE 1482, can be intercompared to better than 5 parts in a million. Its direct-reading inductance accuracy of $\pm 0.1\%$, the ease of balance, and in-line readout make it convenient to use. Although designed primarily for use at frequencies of 1000 c and lower, it can be used, with some decrease in accuracy, to at least 10 kc.

The bridge is well suited for the measurement of inductors with ferromagnetic cores, since its sensitivity makes a balance possible with only a small voltage applied to the inductor, and measurements can thus be made in the region of initial permeability. Measurements of inductors with nonlinear characteristics are further facilitated because in this bridge the voltage across the unknown inductor will not change appreciably when the L and G controls are varied to balance the bridge. The bridge is not suitable for the measurement of incremental inductance at high ac or dc excitation, because the dissipation in the precision resistors in the bridge must be limited to the order of one watt. The

maximum voltage which can be safely applied to the bridge varies from 1 to 100 volts, depending upon the range being used, and these limits are indicated in a table engraved on the bridge panel. The bridge can be used for incremental inductance measurements at levels within these limits, when the desired direct current is supplied to either the generator terminals of the bridge or directly to the unknown. The capacitor C_A blocks the direct current from the R_N standards, and a capacitor connected in series with the internal detector transformer prevents any flow through that path. Use can also be made of the range and resolution of the bridge in making measurements of mutual inductance and of magnetic core materials.

—JOHN F. HERSH

Acknowledgments

Work on a similar Owen bridge was begun some years ago by R. F. Field. Much of the development of the present TYPE 1632-A Bridge is the result of the work of Horatio W. Lamson and of many others of the Engineering Department. After Mr. Lamson's retirement in 1958, the bridge was completed by Ivan G. Easton and John F. Hersh.

SPECIFICATIONS

Range: Range selection is by an eight-position switch, which indicates units and range, and locates the decimal point in the in-line balancing decades.

Full-scale ranges from 111 microhenrys to 1111 henrys for inductance; from 111 micromhos to 1111 mhos for conductance.

Minimum inductance indication is 0.0001 microhenry, which makes possible balances to a precision of 0.1% for inductance as low as 0.1 microhenry.

Inductance Balance: Six, precision decade resistors are used for the inductance balance. Maximum resistance is 100,000 ohms, in 0.1 ohm steps.

Conductance Balance: Four decades of low-loss polystyrene capacitor plus one variable air capacitor. Maximum capacitance is 1.111 μf , minimum capacitance is 200 $\mu\mu\text{f}$.

Sensitivity Switch: An additional control is provided which changes the value of R_B by a factor of 10 without altering the range.

Frequency: Designed primarily for precise and accurate measurements at 1 kc and lower. Usable to at least 10 kc with some decrease in accuracy, see below.

Inductance Accuracy: Basic direct-reading inductance accuracy is $\pm 0.1\%$.

Because of the extremely wide range of the bridge arms, the full accuracy cannot be realized at the extreme of inductance, Q , or frequency.

The direct-reading accuracy is reduced to $\pm 1\%$ on the lowest (a) range, which is provided for the measurement of the very low inductance and high conductance of leads and terminals.



When the Q_X of unknown inductor is low, the accuracy is reduced by an error of $(+0.05 \pm Q_B)\% / Q_X$.

The R_B resistors, switched in decade steps from 1Ω to $100k\Omega$, are compensated to have the small phase angles (expressed as Q_B at 1kc) given in the table.

R_B	1 Ω	10 Ω	100 Ω	1 $k\Omega$	10 $k\Omega$	100 $k\Omega$
Q_B at 1 kc	$\pm 0.03\%$	$\pm 0.005\%$	$\pm 0.002\%$	$\pm 0.002\%$	$\pm 0.02\%$	$\pm 0.1\%$

For frequencies above 1 kc and for the extreme R_B values, the accuracy is reduced by residuals to $0.1 \times 10^{-8}f^2\%$ when $R_B = 1\Omega$ and to $4 \times 10^{-8}f^2\%$ when $R_B = 100k\Omega$.

The capacitance across the unknown terminals is approximately 1pf.

Two nearly equal inductance values can be intercompared to a precision of one part in 10^5 or better.

Conductance Accuracy: The capacitor C_N is adjusted to within $\pm 1\% + 2$ pf.

Errors in conductance arising from residual phase angles of the bridge arms depend upon frequency and Q_X . Such errors are best defined in terms of the dissipation factor of the unknown (reciprocal of Q_X). The error in dissipation factor is less than ± 0.001 at 1 kc, for R_N values less than 10,000 ohms. At higher frequencies the error increases directly with frequency, with R_N , and with R_B . The error can be kept at the ± 0.001 level by reducing the product $R_B R_N$ inversely with frequency. The maximum value of inductance that can be measured

with a given accuracy for conductance (or Q) is thus inversely proportional to frequency.

Circuit: The capacitance decade for resistance balance can be connected in series or in parallel with R_N . Thus the equivalent series or equivalent parallel inductance of the unknown inductor can be measured. For the series connection the maximum value of Q is proportional to frequency, with a maximum value of 60 at 100 cps. For the parallel connection the maximum value of Q is inversely proportional to frequency and R_N . Maximum value at 100 cps and $R_N = 100,000$ ohms is 80. By selection of the R_N value, either series or parallel measurements can be made in most practical cases.

Applied Voltage: Maximum safe applied voltage ranges from 1 volt on the lower inductance ranges to 100 volts on the higher ranges. Values are engraved on the panel.

Accessories Supplied: Two TYPE 274-NL Shielded Patch Cords supplied for connection to generator and detector; TYPE 1632-P1 Transformer, having step-down voltage ratios of 1:22 and 1:5, to match the low bridge input impedance on the *a*, *b*, *c*, *d* ranges to generators requiring a 600 Ω load.

Accessories Required: Generator and detector.

Mounting: Aluminum cabinet and dress panel, crackle finish. Can also be rack mounted.

Dimensions: Panel, 19 x 15 $\frac{3}{4}$ inches; over-all depth, 9 $\frac{3}{8}$ inches.

Net Weight: 40 pounds.

Type		Code Word	Price
1632-A	Inductance Bridge.....	BARGE	\$875.00

HAVE PROTECTION — WILL TRAVEL

General Radio instruments are hardy world travelers. During 1958, for instance, not one instrument per 2000 shipped was reported as damaged in transit to the customer. Considering that most of the material shipped is laboratory test equipment, and that many instruments go halfway around the world by trucks, ships, planes, and trains, there must be a story behind such a record.

First off, the instruments themselves are no softies. Often they are built to stern military specifications and most instruments — military or not — pass a shake test here at GR to prove their ruggedness. Panels and shafts, chassis bracing, knobs, connectors — all are de-

signed not to "get by" but to take years of use, along with some inevitable abuse.

But rugged or not, we can expect that, at the very least, some stevedore in Bazra may not fully appreciate the nature of the cargo he is handling. And as the box is jounced from hold to hold, a hard battle goes on inside—a battle anticipated and planned for weeks before at GR's Shipping Department.

Realizing that ocean shipments are liable to be the most — ah — adventuresome, we pull out all stops when preparing an instrument for such a journey. First, a protective shield — either a wooden cover or a heavy cardboard cover with wooden spacers — is placed

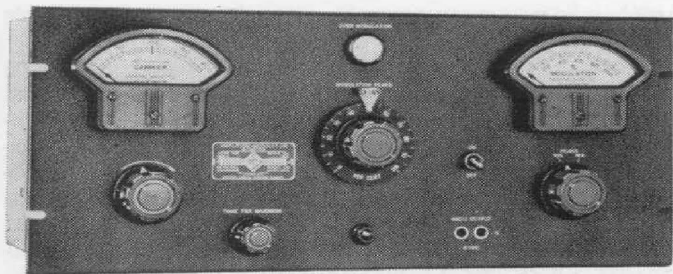

(1) The instrument, a Type 1931-B A-M Monitor.



(2) Paper and wood-reinforced cardboard protect panel.

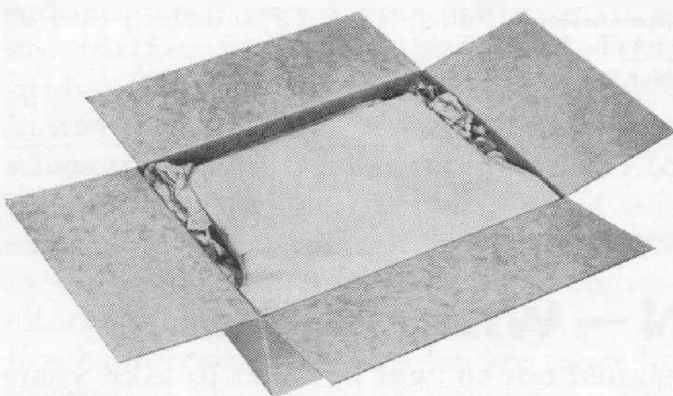

(3) Wrapped and placed in heavy cardboard carton. Accessories, instruction book have been added.

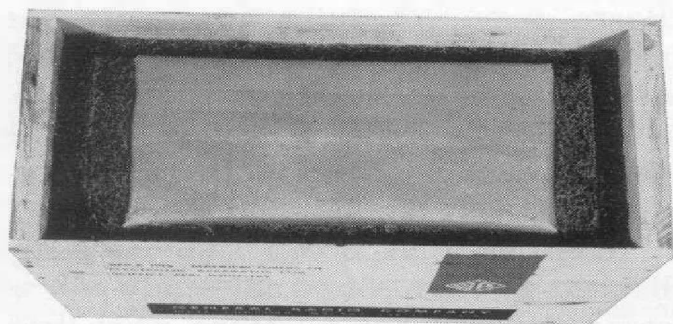

(4) Waterproof bag is placed around carton and evacuated. Then into rugged wooden shipping case, with rubberized fiber pads.

An instrument is readied for a long sea voyage.

over the front panel of the instrument to safeguard the knobs, meters, binding posts, etc. Then the instrument, along with a cushion of heavy kraft paper, is placed in its cardboard stock carton.

The stock carton is then slipped into a close-fitting bag made of a plastic-laminated heavy waterproof paper known as Polykraft. The air is removed from inside the bag, so that it hugs the carton like an undersized bathing suit. This evacuated bag, after heat-sealing, offers protection against moisture, fumes, fungus, etc.

Next, the instrument in a box in a bag is nestled into its wooden packing case, with two-inch-thick rubberized fiber pads inserted as shock absorbers on all six surfaces. The wooden crate is finally steel-strapped and marked with appropriate shipping instructions. These may include, at the request of the customer, a bright green band, a red diamond, a blue crescent, or other unique marks to help the consignee spot his shipment at the place of unloading.

The multilayered protection described above is not usually necessary for air shipments. Also, such elaborate crating would add measurably to the customer's shipping expense by air, whereas with ocean shipment weight is a less critical



(5) Top pads have been added, lid secured, box strapped, and labeled.



cost factor. Thus, for air and most domestic shipments, instruments are usually sent in their stock cartons. Our extremely low damage rate indicates

that, no matter what the destination or the transportation, our packaging will see it there safely.

— F. T. VAN VEEN

DELAY-LINE OSCILLATOR

A Novel Circuit for a 1 to 20-Mc Single-Range Oscillator

A novel use for a variable delay line is illustrated in the schematic diagram of Figure 1. The circuit utilizes the delay line as the feed-back element of a triode oscillator. The delay line may be thought of as a phase-shift network having 180° phase shift at a frequency corresponding to twice the delay time and its odd harmonics.

A simpler physical picture of the circuit operation is obtained from a time-domain description. Let us assume that the triode is suddenly biased to cutoff by a negative voltage step at its grid. A positive voltage step will occur at the plate. This positive step travels down the delay line and is coupled back to the grid by the coupling capacitor, turning the triode on. A negative voltage step then occurs at the plate, which travels down the delay line, cutting the triode off, and the process repeats.

With a large value of coupling capacitor, the grid and plate voltage wave-

forms are essentially rectangular, and the amplitudes are fairly constant over the entire range owing to the on-off nature of the oscillations. With a small value of coupling capacitor, the oscillations are more nearly sinusoidal and smaller in amplitude.

The circuit shown, utilizing a General Radio TYPE 314-S86 Variable Delay Line¹ (0 to 0.5- μ sec), oscillates readily up to about 30 Mc. The grid voltage waveforms at frequencies of 1, 5, and 20 Mc are shown in Figure 3. The upper end of the frequency range is quite crowded because of the hyperbolic relationship between the frequency of oscillation and the shaft rotation of the linear delay line ($f = \frac{1}{2T}$). Up to about 20 Mc, however, operation is quite smooth and uniform. The lower end of the frequency range is limited by the maximum delay of the line (1 Mc for

¹F. D. Lewis, R. M. Frazier, "A New Type of Variable Delay Line," *General Radio Experimenter*, Vol. 31, No. 5, October, 1956.

Figure 1. Schematic of the delay-line oscillator.

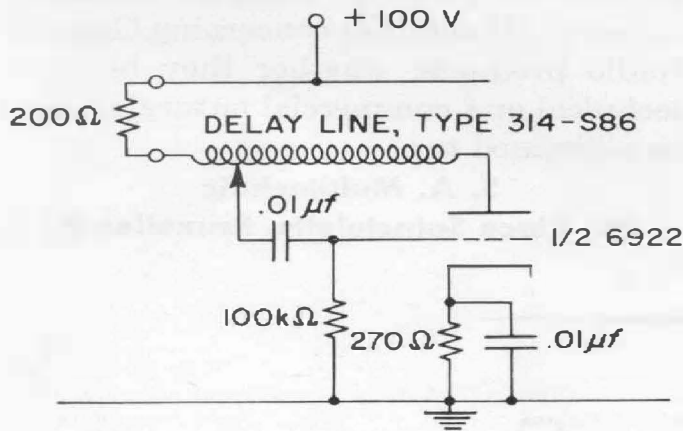
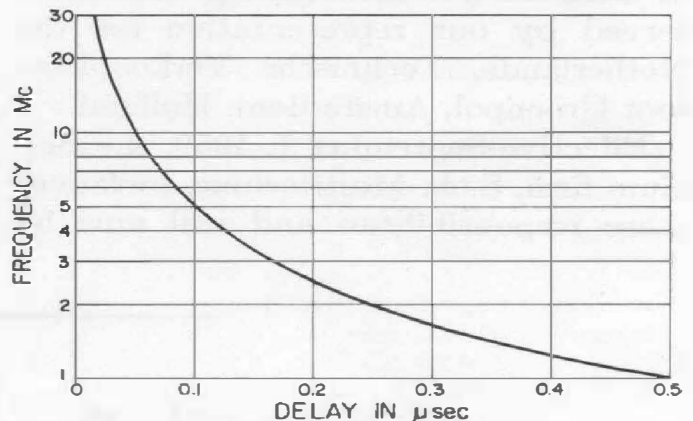

Figure 2. Plot of frequency vs. delay setting.



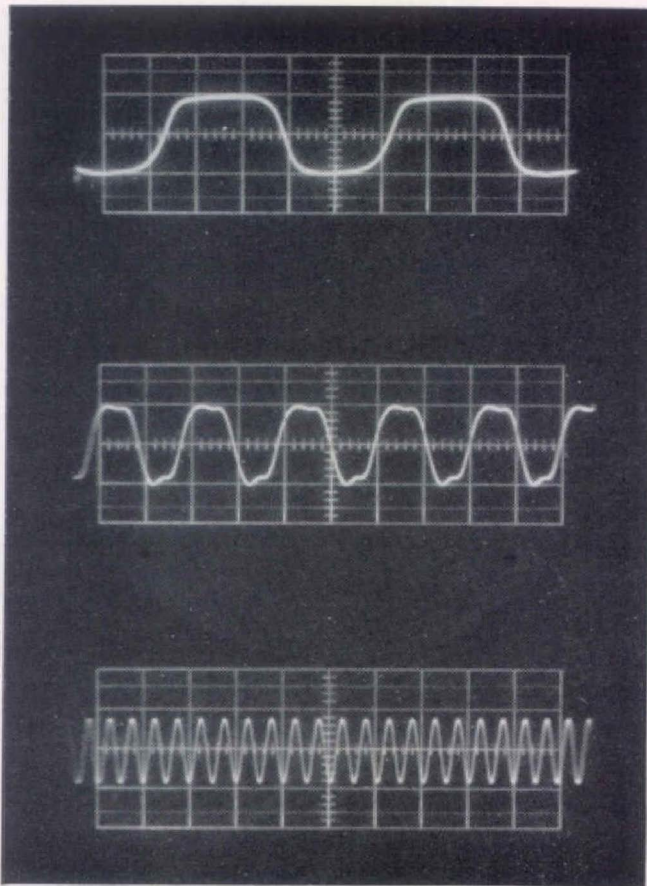

Figure 3. Grid-voltage waveforms.

(a) 1 Mc. Vertical scale, 2 volts/cm. Horizontal scale, 0.2 μ sec/cm.

(b) 5 Mc. Vertical scale, 2 volts/cm. Horizontal scale, 0.1 μ sec/cm.

(c) 20 Mc. Vertical scale, 2 volts/cm. Horizontal scale, 0.1 μ sec/cm.

(Tektronix Type 543 Oscilloscope)

the TYPE 314-S86). Since the frequency of oscillation depends primarily upon the delay line and is relatively inde-

pendent of the tube characteristics, it is quite stable at any particular setting of the line.

— H. T. McALEER

NEW REPRESENTATIVE FOR BELGIUM AND LUXEMBURG

In the past the needs of our customers in Belgium and Luxemburg have been served by our representative for the Netherlands, Technische Verkoopkantoor Groenpol, Amsterdam, Holland.

Effective September 1, 1959, the Belgium firm, S. A. Multitechnic, took over these responsibilities and will now be

serving directly our customers and prospective customers in Belgium and Luxemburg. All inquiries concerning General Radio products, whether they be of a technical or a commercial nature, should be addressed to:

S. A. Multitechnic
30, Place Saintelette, Bruxelles 8

General Radio Company